

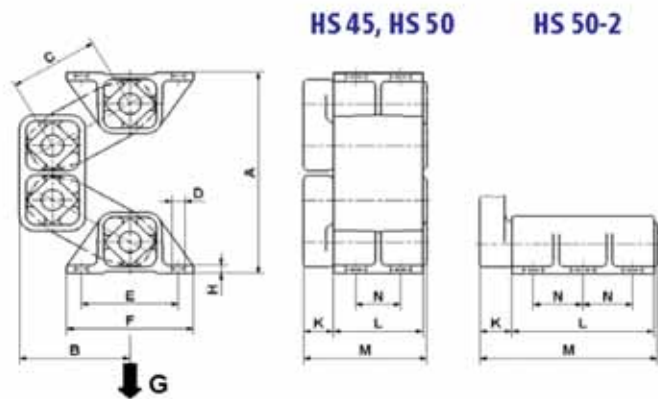

Suspensión Oscilante

Tipo HS

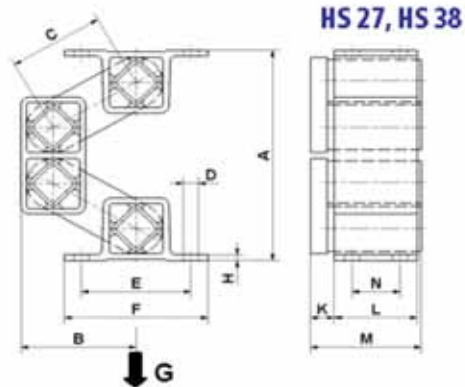

Art. No.	Tipo	G	A sin carga	A* max. carga	B sin carga	B* max. carga	C	D	E	F	H	K	L	M	N	Peso kg
07311 001	HS 27	500 - 1250	164	201	84	68	70	∅ 11	80	105	4.5	17	60	80	35	1.6
07311 002	HS 38	1200 - 2500	223	275	114	92	95	∅ 13	100	125	6	21	80	104	40	4.9
07311 003	HS 45	2000 - 4200	265	325	138	112	110	13x20	115	145	8	28	100	132	65	11.3
07311 004	HS 50	3500 - 8400	288	358	148	118	120	17x27	130	170	12	40	120	165	60	20.2
07311 005	HS 50-2	6000 - 14000	288	355	148	120	120	17x27	130	170	12	45	200	250	70	34.0

G = Capacidad de carga por soporte en N
 * Valores con la carga incluida

Material de fabricación

	HS 27, HS 38	HS 45	HS 50, HS 50-2
Aluminio, aleación ligera	x	x	
Fundición modular			x
Fundición de acero soldado	x	x	
Pintados de azul ROSTA	x	x	x

